

## SEMI-AUTO BUTT FUSION WELDING MACHINE



## Instruction Manual

SHD800-I



SHD1000-I



SHD1200-I



# CONTENTS

1. Brief .....	1
2. Special Description .....	1
3. Safety.....	2
4. Applicable Range and Technical Parameter .....	6
5 . Descriptions .....	7
6. Instruction for Use .....	9
7. Timer and Temperature Controller .....	12
8. Reference of Welding Standard (DVS2207-1-1995) .....	14
9. Malfunctions Analyses and Solutions .....	15
10. Electrical draw diagram and Hydraulic schematic diagram.....	19
11. Accessories list.....	21
12. Guarantee Clauses.....	24
Welding parameter .....	25

## 1. Brief

Along with the property of PE material continuous perfecting and raising, PE pipes are extensively used in gas and water supply, sewage disposal, chemical industry, mine and so on. For more than ten years, our factory has been researching and developing SH series plastics pipe butt fusion machine that is suit for PE, PP, and PVDF. We have fulfilled the techniques requirements of ISO12176-1. Our products have outstanding features in convenience, reliability, safety and lower price.

Today, our products include nine kinds and over than 20 types that can be applied to plastics pipe construction and make fittings in workshop as follow:

- \* Socket welder
- \* Manual butt fusion machine
- \* Butt fusion machine
- \* Auto-butt fusion machine
- \* Band saw
- \* Workshop butt fusion machine
- \* special tools
- \*Saddle fusion machine

This manual is suit for SHD800/1000/1200-I plastic pipe butt fusion welding machine. It's suggested to read and follow carefully the following safety rules and maintenance rules before operating the machine.

## 2. Special Description

Before operating the machine, anyone should read this description carefully and keep it well to ensure the equipment and operator's safety, as well as others' safety.

2.1 The machine is used to weld pipes made from PE, PP, PVDF and can not be used to weld material without description, otherwise the machine may be damaged or some accident may be resulted in.

2.2 Don't use the machine in a place with potential hazard of explosion

2.3 The machine should be operated by responsible, qualified and trained personnel.

2.4 The machine should be operated on a dry area. The protective measures should be adopted when it is used in rain or on wet ground.

2.5 The machine is operated by 380V±10%, 50/60 Hz. If extended wire should be used, it should have enough lead section according its length.

2.6 Before using the machine, fill 46# hydraulic oil. Make sure the hydraulic oil is enough for working; the oil level should be 2/3 of the tank. Replace the iron oil tank cap by the red plastic air bleed cap or the pressure can not be hold.



## 3. Safety

### 3.1 safety marks

The following marks are affixed to the machine:

Hot! Keep distance from parts with this sign, for they are very hot!



Danger, Electrical shock  
Parts with this sign have a danger of electricity leak.  
Be careful when working here.



No approaching! Moving parts can crush. Keep fingers, feet, arms, legs, and head out of the jaw area between the moving tables.



Caution, injure hand



Caution, heavy



### 3.2 Precautions for Safety

Take care when operating and transporting the machine according to all the safety rules in this instruction.

#### 3.2.1 Notice when using

- The operator should be responsible and trained personnel.
- Completely inspect and maintain the machine per year for the safety and machine's reliability.
- Dirty and crowded work site would not only lower working efficiency, but cause accident easily, so it is important to keep work site clean and no other obstacles

### 3.2.2 Power

The electricity distribution box should have ground fault interrupter with relevant electricity safety standard. All safety protection devices are indicated by easily understandable words or marks.

Earthing: The whole site should share the same ground wire and the ground connection system should be completed and tested by professional people.

### 3.2.3 Connection of machine to power

The cable connecting machine to power should be mechanical concussion and chemical corrosion proof. If the extended wire is used, it must have enough lead section according to its length.

### 3.2.4 Storage of electrical equipment

For the min. dangers, all equipment must be used and stored correctly as follows:

- ※ Avoid using temporary wire not complying with standard
- ※ Do not touch electrophorus parts
- ※ Forbid hauling off the cable to disconnect
- ※ Forbid hauling cables for lifting equipment
- ※ Do not put heavy or sharp object on the cables, and control the temperature of cable within limiting temperature (70°C)
- ※ Do not work in the wet environment. Check if the groove and shoes is dry.
- ※ Do not splash the machine

### 3.2.5 Check insulation condition of machine periodically

- ※ Check the insulation of cables specially the points extruded
- ※ Do not operate the machine under extreme condition.
- ※ Check if the leakage switch works well at least per week.
- ※ Check the earthing of the machine by qualified personnel

### 3.2.6 Clean and check the machine carefully

- ※ Do not use materials (like abrasive, and other solvents) damaging the insulation easily when cleaning the machine.
- ※ Make sure the power is disconnected when finishing job.
- ※ Make sure there is no any damage in the machine before reusing.

If only following above mentioned, the precaution can work well.

### 3.2.7 Starting

Make sure the switch of the machine is closed before powering it on.

### 3.2.8 Tightness of parts

Make sure the pipes are fixed correctly. Ensure that it can move well and prevent it from sliding down.

### 3.2.9 Work in environment with hazards

When work in a ditch, check if there is fender which stop the earth or stones from falling down to the machine, and also check if it has a water or other fluid leaking, if there be, the operator may get an electric shock.

When lift the machine to ditch, the weight of the machine should be within the rated lifting weight, and person is forbidden staying under the lifting arm.

Avoid using the machine in the environment full of paint, gas, smoke and deoil, since the infection of eyes and respiratory tract would be caused.

Do not put the machine in a dirty place.

### 3.2.12 Personnel safety while working

Remove jewelry and rings, and does not wear loose-fitting clothing avoid wearing shoe lace, long mustache or long hair that may be hooked into the machine

The following is the operation rules:

---Wear safety groove



---Wear safety shoes



---Dress work clothes



---Wear safety glasses



---Wear earmuffs



3.2.14 Untrained person is not allowed to operate the machine anytime.

### 3.3. Potential Dangers

#### 3.3.1 Butt fusion machine controlled by hydraulic unit:

This machine is only operated by professional person or others with a certificate for operation, otherwise unwanted accident maybe caused.

#### 3.3.2 Heating Plate

The max temperature can reach 270°C, so the following things should be noticed:

-----Wear safety groove



-----Never touch the surface of the heating plate



#### 3.3.3 Planing tool

Before shaving the pipes, ends of pipes should be cleaned, especially clean the sand or other draff crowd around the ends. By doing this, the lifetime of edge can be prolonged, and also prevent the shavings are thrown out to danger people.

#### 3.3.4 Basic Frame:

Make sure the pipes or fittings are fixed correctly to get the right alignment. When joining pipes, the operator should keep a certain space to the machine for personnel safety.

Before transporting, make sure all the clamps are fixed well and can not fall down during transportation.

Follow all the safety marks in the machine.

## 4. Applicable Range and Technical Parameter

Type	SHD800-I	SHD1000-I	SHD1200-I
Materials	PE, PP, PVDF		
Max. range of diameter	450mm~800 mm	630mm-1000mm	630-1200mm
Ambient temp.	-5~45°C		
Power supply	~380 V±10 %, 50 Hz		
Total current	28A	43A	60A
Total power	18.2kW	24 kW	29.5 kW
Include :Heating plate	12.5 kW	17.5 kW	21.5 kW
Planing tool motor	2.2 kW	3 kW	4 kW
Hydraulic unit motor	3 kW	3 kW	3 kW
Crane power	0.5KW	0.5KW	1KW
Dielectric resistance	>1MΩ		
Max. Pressure	≤16MPa	≤16MPa	≤16MPa
Total section of cylinders	44cm <sup>2</sup>	38.9cm <sup>2</sup>	50.7 cm <sup>2</sup>
Volume of oil box	4L		
Hydraulic oil	270°C		
Undesired sound	±5°C		
Max. Temperature of heating plate	40~50 (kinematic viscosity)mm <sup>2</sup> /s, 40°C		
Difference in surface temperature of heating plate	<70 dB		
Weight	1454	2600	4500

\* The special voltage is based on the actual voltage.

## 5 . Descriptions

The machine consists of basic frame, hydraulic unit, heating plate, Planing tool, and support.

### 5.1 Structure



1. Hydraulic unit

2. Basic frame

3. Support

4. Heating plate

5. Planing tool

## 5.2 Hydraulic Unit

### 5.2.1 Hydraulic unit

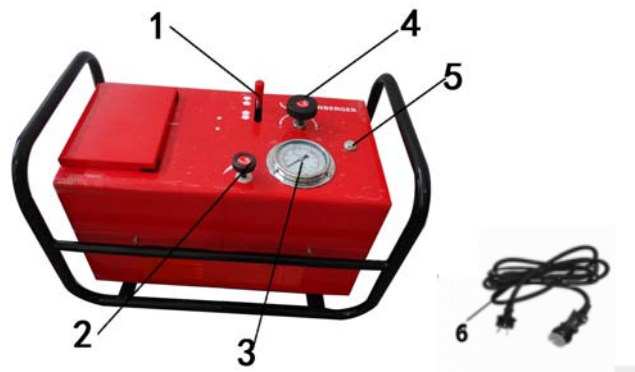

- |                      |                              |                   |
|----------------------|------------------------------|-------------------|
| 1. Direction valve   | 2. Pressure regulation valve | 3. Pressure gauge |
| 4. Swing check valve | 5. Oil hole                  | 6. Power cable    |

### 5.2.2 Hydraulic unit operation panel



- |                           |          |                  |
|---------------------------|----------|------------------|
| 1. Temperature controller | 2. Timer | 3. Heater switch |
|---------------------------|----------|------------------|

### 5.2.3 Hydraulic unit sockets



- |                    |                         |                 |                 |                |
|--------------------|-------------------------|-----------------|-----------------|----------------|
| 1. Planning socket | 2. Heating plate socket | 3. Power socket | 4. Hoist Socket | 5. Data logger |
|--------------------|-------------------------|-----------------|-----------------|----------------|

## 6. Instruction for Use

6.1 The whole equipment should be placed on a stable and dry plane to operate.

6.2 Before operation make sure the following things:

- ◆ The machine is in good conditions
- ◆ The power complies with the requirements according to the butt fusion machine
- ◆ Power line is not broken or worn
- ◆ All instruments are normal
- ◆ The blades of planning tool are sharp
- ◆ All necessary parts and tools are available

6.3 Connection and preparation

6.3.1 Connect the basic frame to hydraulic unit by quick couplers.



6.3.2 Connect the heating plate to the hydraulic unit with the special cable.



Connection the cable with electrical box

Connection between the cable and heating plate

6.3.3 Install appropriate inserts to frame according to the outside diameter of pipes/fittings.

6.3.4 According to the requirements of fitting and welding process, set the temperature in temperature controller and set time in timer. (See section 7 this manual).

## 6.4 Welding Steps

### 6.4.1 Pipes

Before welding, firstly, check if the material and its pressure grade are the required ones. Secondly check if there are scratches or fissures on the surface of pipes/fittings. If the depth of scratches or fissures exceeds 10% of the wall thickness, cut the section of scratches or fissures. Clean the pipe end's surfaces with clean cloth to keep the pipe's ends clean.

### 6.4.2 Clamping

Place the pipes/fittings in inserts of frame and keep the ends to be welded be the same length (no effect on the planning and heating of the pipe). The pipe out of the basic frame should be supported to the same central axial of clamps. Fasten the screws of clamps to fix the pipes/fittings.

### 6.4.3 Adjust the pressure

### 6.4.4 Planing

Open the pipes/fittings ends after turning swing check valve anti-clockwise to the end. Put the planning tool between the pipes/fittings ends and switch it on, close the pipes/fittings ends by acting on the direction valve meanwhile slowly turn swing check valve clockwise until there are continuous shavings appearing on both sides. Turn the swing valve anti clockwise to relief the pressure, in a moment later open the frame, switch off the planing tool and remove it.

Close the pipes/fitting ends and checks the alignment of them. The maximal misalignment should not exceed 10% of the wall thickness, and it could be improved by loosening or tightening the screws of clamps. The gap between two pipe ends should not exceed 10% of wall thickness; otherwise the pipes/fittings should be planed again.

Caution: The shavings thickness should be within 0.2~0.5 mm and it can be adjusted by adjusting the height of the planning tool blades.

### 6.4.5 Heating

Clear the dust or slit on the surface of heating plate (Caution: Don't damage PTFE layer on the surface of heating plate.), and make sure the temperature has reached the required one.

Put the heating plate between the pipe ends after it reaches required temperature. Close the pipes/fittings ends by operating direction valve and raise the pressure to specified pressure by swinging pressure regulation valve till the bead reaches specified height.

Turn swing check valve anti-clockwise to reduce the pressure (not more than drag pressure) and turn swing check valve in clockwise direction to the end.

#### 6.4.6 Joining and cooling

Open the frame and take out the heating plate and close two melting ends as quickly as possible.

Keep the bar of direction valve on the close position for 2~3 minutes, put the bar of direction valve on middle position. At this point, the machine will give an alarm again. Relief the pressure, loose the screw of clamps and then take out the jointed pipes.

Common welding Sketch

	<p>Long pipe welding</p>
	<p>Short flange&amp;Long pipe</p>
	<p>Short flange&amp;Pipe fitting</p>
	<p>Socket pipe&amp;Long pipe</p>
	<p>Elbow pipe&amp;Long pipe</p>

## 7. Timer and Temperature Controller

If one of the parameters is changed, such as outside diameter, SDR or material of pipes, the soaking time and cooling time should be reset according to the welding standard.

### 7.1 Temperature controller setting

#### (1) Temperature controller setting

Switch on

Press "SET" for more than 4 seconds till "Sd" is shown in the upper window

Press "△" or "▽"key, enter the setting temperature, and press "SET" to confirm

#### (2) Deviation Correction of temperature Control instrument

Switch on



Press "SET" for more than 3 seconds till "SI" is shown in the upper window



Press "SET" till "SC" is shown in the upper window



Press "△" or "▽"key, enter temperature correction value, press "SET" key to confirm



## 8. Reference of Welding Standard (DVS2207-1-1995)

8.1 Because of difference in welding standard and PE material, the time and pressure vary in different phases of welding. It suggests that the actual welding parameters should be offered by pipes and fittings' manufacturers.

8.2 Given welding temperature of pipes made from PE、PP and PVDF by DVS standard ranges from 180°C to 270°C. Application temperature of heating plate is within 180~230°C, and its max. surface temperature can reach 270°C.

8.3 Reference standard DVS2207-1-1995

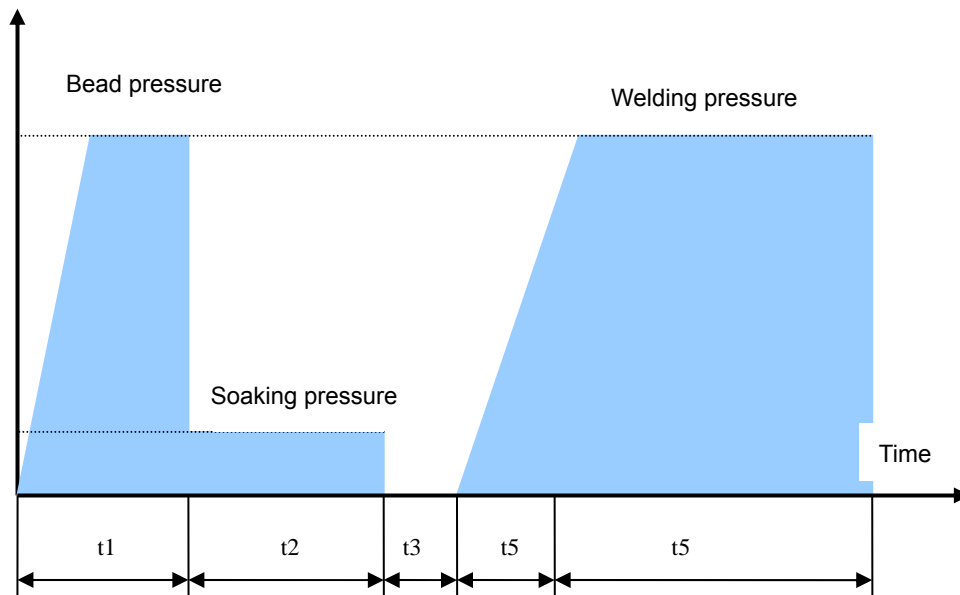

Pipe diameter	Wall thickness	Bead build-up pressure	Bead height	Soaking pressure	Soaking time	Change-over time	Pressure build-up time	Welding pressure	Cooling time
D	e	P1	H	P2	t3	t4	t5	P3	t5

(Bead build-up pressure) Welding pressure = (P1) P3+Drag pressure

$$\text{welding pressure} = \frac{\text{Section of welding pipe ends}}{\text{Total section of cylinders}} \times 0.15 + \text{Drag pressure (MPa)}$$

$$\text{Section of welding pipe ends} = 3.14 \times (\text{Pipe diameter} - \text{Wall thickness}) \times \text{Wall thickness}$$

Note: The drag pressure is not more than 50% of the welding pressure.

## 9. Malfunctions Analyses and Solutions

### 9.1 Frequent joints quality problems analyze:

- ◆ Visually check: round bead, good joint



- ◆ Narrow and fall bead. Too high pressure while welding



- ◆ Too small bead. Pressure is not enough while welding



- ◆ There is a ditch between the welding surfaces. Temperature is not enough or change-over time is too long while welding.



- ◆ High & low bead. Different heating time or fusion temperature causes that.



- ◆ Misalignment. Welding under the condition that the misalignment exceeds 10% of pipe wall thickness while align the two ends.



## 9.2.2 Maintenance & Inspection

### Ordinary inspection

Item	Description	Inspect before use	First month	Every 6 months	Every year
Planning tool	Mill or replace the blade Replace the cable if it is broken Retighten mechanical connections	• •	•		• •
Heating plate	Rejoined the cable and socket Clean surface of heating plate, recoat PTFE layer again if necessary Retighten mechanical connections	• • •	•		•
Temp. control system	Checkout the temperature indicator Replace the cable if it is broken	•			• •
Hydraulic system	Checkout pressure gauge Replace seals if the hydraulic unit is leak Clean the filter Make sure the oil is enough for operation Change the hydraulic oil Replace if the oil hose is breakage	• • •		•	• • • •
Basic Frame	Retighten screws in the end of frame axis Spray antirust paint again if necessary	•	•	•	•
Power Supply	Press the testing button of circuit protector to make sure it can working normally Replace the cable if it is broken	• •		•	

“•” ..... maintenance period

### 9.3 Frequent malfunction analyses and solutions

During the using, hydraulic unit and electrical units may appear some problems. Frequent malfunction is listed as follows:

Please use tools attached, spare parts or other tools with a safety certificate while maintain or replace parts. Tools and spare parts without safety certificate are forbidden to be used.

Malfunctions of hydraulic unit			
No	malfunction	malfunction analyzes	Solutions
1	The pump motor does not work	<ol style="list-style-type: none"> <li>1. switch is fault.</li> <li>2. Power source is not connected well.</li> <li>3. The socket inside connection is loosen</li> <li>4. The machine is not grounded correctly</li> </ol>	<ol style="list-style-type: none"> <li>1. Check the switch</li> <li>2. Connect the power well</li> <li>3. Check the connection</li> <li>4. Check the earthing connection</li> </ol>
2	The pump motor rotate too slowly with abnormality noise	<ol style="list-style-type: none"> <li>1. The motor is overloaded</li> <li>2. The motor is fault</li> <li>3. The oil filter is blocked</li> <li>4. The working voltage is instable</li> </ol>	<ol style="list-style-type: none"> <li>1. Make sure the motor load is less that 3 MPa</li> <li>2. Repair or replace the pump</li> <li>3. Clean the filter</li> <li>4. Check the instability of power</li> </ol>
3	The cylinder works abnormally	<ol style="list-style-type: none"> <li>1. The direction valve is damaged</li> <li>2. There is air in system</li> <li>3. The system pressure is too low</li> <li>4. The quick coupler is blocked</li> <li>5. The pressure relief valve is not locked</li> </ol>	<ol style="list-style-type: none"> <li>1. Replace the direction valve.</li> <li>2. Move the cylinder several times to outgo the air.</li> <li>3. Adjust the system pressure</li> <li>4. Replace the quick coupler</li> <li>5. Lock the valve</li> </ol>
4	Cylinder leak	<ol style="list-style-type: none"> <li>1. The oil ring is fault</li> <li>2. The cylinder or piston is damaged badly</li> </ol>	<ol style="list-style-type: none"> <li>1. Replace the oil ring</li> <li>2. Replace the cylinder</li> </ol>
5	The pressure can not be increased or the fluctuation is too big	<ol style="list-style-type: none"> <li>1. The core of overflow valve is blocked.</li> <li>2. The pump is leak.</li> <li>3. The joint slack of pump is loosened or key groove is skid.</li> <li>4. The pressure relief valve is not locked</li> </ol>	<ol style="list-style-type: none"> <li>1. Clean or replace the core of over-flow valve</li> <li>2. Replace the pump</li> <li>3. Replace the joint slack</li> <li>4. Lock the valve</li> </ol>

Malfunctions of electrical units			
1	The machine does not work	<ol style="list-style-type: none"> <li>1. The power cable is damaged</li> <li>2. Source power is abnormal</li> <li>3. The ground fault switch is closed</li> </ol>	<ol style="list-style-type: none"> <li>1. Check the power cable</li> <li>2. Check the working power</li> <li>3. Open the ground fault interrupter</li> </ol>
2	Ground fault switch trips	<ol style="list-style-type: none"> <li>1. Power cable of heating plate, the motor of pump and planing tool may be damaged</li> <li>2. Electrical components are t affected with damp</li> <li>3. The higher-up power has not a ground fault safety device</li> </ol>	<ol style="list-style-type: none"> <li>1. Check the power cables</li> <li>2. Check the electrical elements.</li> <li>3. Check the higher-up power safety device</li> </ol>
3	Abnormal temperature increasing	<ol style="list-style-type: none"> <li>1. The temperature controller switch is open</li> <li>2. The sensor (pt200) is abnormal. The resistance value of 4 and 5 of heating plate socket should be within 100~183Ω</li> <li>3. The heating stick inside heating plate is abnormal. The resistances between 2 and 3 should be within 23Ω. Insulation resistance between head of heating stick and outside shell must be more than 1MΩ</li> <li>4. Should the temperature controller readings be more than 300℃, which suggest he sensor may be damaged or the connection is loosen. Should the temperature controller indicate LL, which suggests the sensor have a short circuit. Should the temperature controller indicate HH, which suggests the circuit of sensor is open.</li> <li>5. Correct the temperature by button located on the temperature controller.</li> <li>6. The temperature fluctuate abnormally</li> </ol>	<ol style="list-style-type: none"> <li>1. Check the connection of contactors</li> <li>2. Replace the sensor</li> <li>3. Replace the heating plate</li> <li>4. Replace the temperature controller</li> <li>5. Refer to the methods to set the temperature</li> <li>6. Check and replace the contactors if necessary</li> </ol>
4	Lose of control when heating	The red light is shine, but the temperature still goes up, that is because the connector is fault or the joints 7 and 8 can not open when get the required temperature.	Replace the temperature controller
5	Planing tool does not rotate	The limit switch is ineffective or the mechanical parts of planing tool are clipped.	Replace the planning tool limit switch or minor sprocket

# 10、 Electrical draw diagram and Hydraulic schematic diagram

## 10.1 Electrical draw diagram

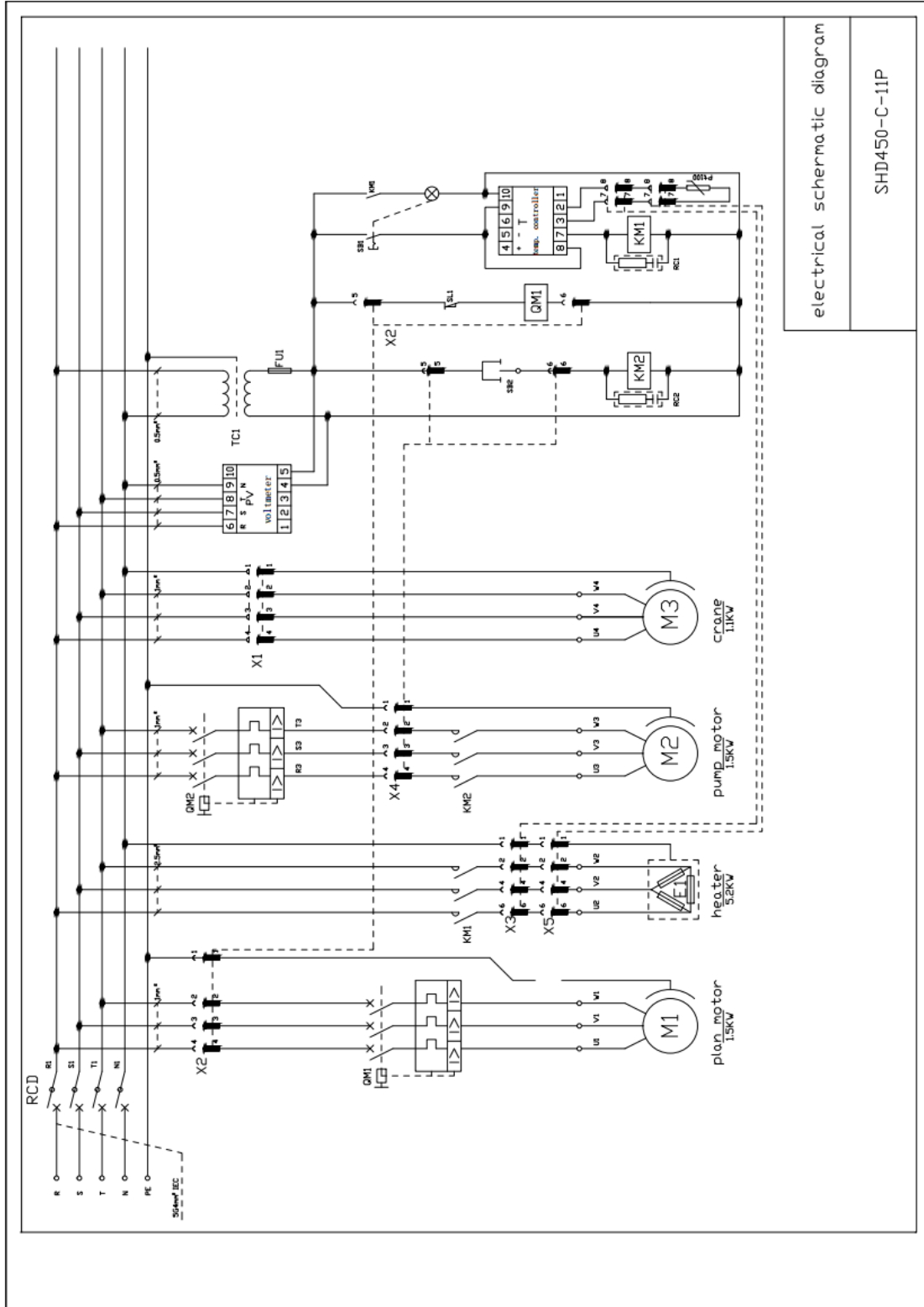

electrical schematic diagram

SHD450-C-11P

10.2 Hydraulic schematic diagram

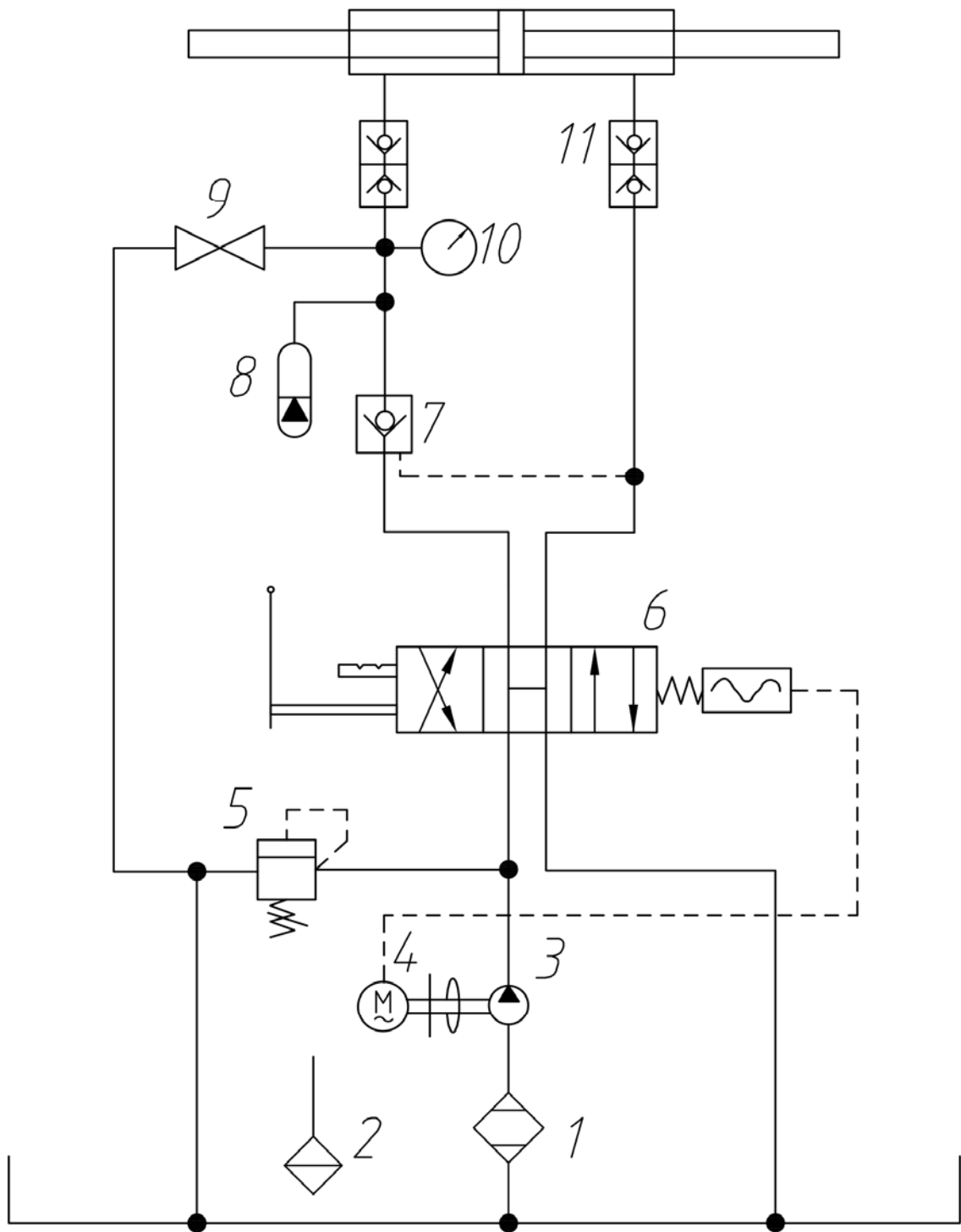

## 11、Accessories list

### SHD800/450-I Butt fusion welding machine

Item	Description	Unit	Qty	Remark
1	Basic frame	set	1	4pcs bottom clamp
2	Inserts	set	1	Φ710,Φ630, Φ560,Φ500Φ450
3	Stub end device for short flange	set		Optional
4	Single clamp	set		Optional
5	Hydraulic unit	set	1	Include 2pcs high-pressure oil hose
6	Support	set	1	
7	Planing tool	set	1	
8	Heating plate	set	1	Include 1 pcs connecting cable of heating plate
9	Crane	set	1	
Attachment with machine				
1	Hexagon socket head bolts (M10)	set	1	L = 40、80、120、150、175 (10pcs/each spec)
2	Double open wrench	pcs	1	22X24
3	Adjustable wrench	pcs	1	18"
4	Hexagon wrench	pcs	1	8mm
5	Hexagon wrench	pcs	1	10mm
6	Hexagon wrench	pcs	1	12mm
7	Special screw bolt	Set	2	SHD800
8	Fuse	Pcs	1	2A
9	Oil plug	pcs	1	
10	Cutter of planning tool	Pcs	2	SHD800
11	Product qualification certificate	pcs	1	
12	Operation instruction	pcs	1	

### SHD1000/630-I Butt fusion welding machine

Item	Description	Unit	Qty	Remark
1	Basic frame	set	1	4pcs bottom clamp
2	Inserts	set	1	Φ900,Φ800,Φ710, Φ630
3	Stub end device for short flange	set		Optional
4	Single clamp	set		Optional
5	Hydraulic unit	set	1	Include 2pcs high-pressure oil hose
6	Support	set	1	
7	Planing tool	set	1	
8	Heating plate	set	1	Include 1 pcs connecting cable of heating plate
9	Crane	set	1	
Attachment with machine				
1	Hexagon socket head bolts (M10)	set	1	L = 50、100、150、200 (10pcs/each spec)
2	Double open wrench	pcs	1	22X24
3	Adjustable wrench	pcs	1	18"
4	Hexagon wrench	pcs	1	8mm
5	Hexagon wrench	pcs	1	10mm
6	Hexagon wrench	pcs	1	12mm
7	Special screw bolt	Set	2	SHD1000
8	Nylon ropeΦ6	米	10	Φ6
9	Fuse	Pcs	1	2A
10	Oil plug	pcs	1	
11	Cutter of planning tool	Pcs	2	SHD1000
12	Product qualification certificate	pcs	1	
13	Operation instruction	pcs	1	

### SHD1200/630-I Butt fusion welding machine

Item	Description	Unit	Qty	Remark
1	Basic frame	set	1	4pcs bottom clamp
2	Inserts	set	1	Φ1100,Φ1000,Φ900,Φ800,Φ710, Φ630
3	Stub end device for short flange	set		Optional
4	Single clamp	set		Optional
5	Hydraulic unit	set	1	Include 2pcs high-pressure oil hose
6	Support	set	1	
7	Planing tool	set	1	
8	Heating plate	set	1	Include 1 pcs connecting cable of heating plate
9	Crane	set	1	
Attachment with machine				
1	Hexagon socket head bolts (M10)	set	1	L= 50、100、155、200、250、290 (10pcs/each spec)
2	Double open wrench	pcs	1	22X24
3	Adjustable wrench	pcs	1	18"
4	Hexagon wrench	pcs	1	8mm
5	Hexagon wrench	pcs	1	10mm
6	Hexagon wrench	pcs	1	12mm
7	Special screw bolt	Set	2	SHD1200
8	Nylon ropeΦ6	米	10	Φ6
9	Fuse	Pcs	1	2A
10	Oil plug	pcs	1	
11	Cutter of planning tool	Pcs	2	SHD1200
12	Product qualification certificate	pcs	1	
13	Operation instruction	pcs	1	

## 12、 Guarantee Clauses

1. The guarantee range refers to the whole machine.
2. Maintenance for malfunctions during normal utilization is free of charge within guarantee time that is 12 months
3. The guarantee time starts with the date of delivery.
4. Fees are charged in case of the following condition:
  - 4.1 Malfunction caused by improper operation
  - 4.2 Damages caused by fire, flood, and abnormal voltage
  - 4.3 Working exceeds its normal function
5. Fees are charged as actual expense. A contract about the fees shall be abided if there is one.
6. Please contact us or our agent if any questions.

## Welding parameter

PE T=220°C      DVS 2207/T1 (8/15)

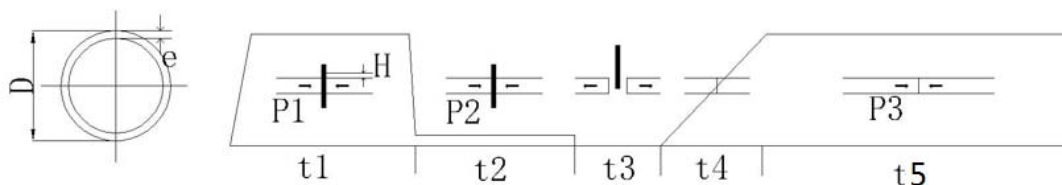

**SHD800-I (Cylinder area=44cm<sup>2</sup>)**

D (mm)	SDR	e(mm)	P1(bar)	H(mm)	P2(bar)	t2(sec)	t3(sec)	t4(sec)	P3(bar)	t5(min)
450	9	50.0	21.4	3.5	1.4	500	19	24	21.4	61
	11	40.9	17.9	3.5	1.2	409	16	19	17.9	50
	13.6	33.1	14.8	3	1.0	331	14	17	14.8	40
	17	26.5	12.0	3	0.8	265	12	14	12.0	33
	17.6	25.6	11.6	2.5	0.8	256	12	14	11.6	32
	21	21.4	9.8	2.5	0.7	214	10	11	9.8	26
	26	17.3	8.0	2	0.5	173	9	10	8.0	22
	33	13.6	6.4	2	0.4	136	8	8	6.4	17

D (mm)	SDR	e(mm)	P1(bar)	H(mm)	P2(bar)	t2(sec)	t3(sec)	t4(sec)	P3(bar)	t5(min)
500	9	55.6	26.4	4	1.8	556	20	25	26.4	68
	11	45.5	22.1	3.5	1.5	455	18	22	22.1	57
	13.6	36.8	18.2	3	1.2	368	15	18	18.2	45
	17	29.4	14.8	3	1.0	294	13	15	14.8	35
	17.6	28.4	14.3	3	1.0	284	13	15	14.3	34
	21	23.8	12.1	2.5	0.8	238	11	13	12.1	30
	26	19.2	9.9	2.5	0.7	192	10	11	9.9	24
	33	15.2	7.9	2	0.5	152	9	10	7.9	20

D (mm)	SDR	e(mm)	P1(bar)	H(mm)	P2(bar)	t2(sec)	t3(sec)	t4(sec)	P3(bar)	t5(min)
560	9	62.2	33.2	4	2.2	622	22	29	33.2	76
	11	50.9	27.7	4	1.8	509	19	24	27.7	62
	13.6	41.2	22.9	3.5	1.5	412	16	19	22.9	50
	17	32.9	18.6	3	1.2	329	14	17	18.6	40
	17.6	31.8	18.0	3	1.2	318	14	17	18.0	39

	21	26.7	15.2	3	1.0	267	12	14	15.2	33
	26	21.5	12.4	2.5	0.8	215	10	11	12.4	28
	33	17.0	9.9	2	0.7	170	9	10	9.9	22
D (mm)	SDR	e(mm)	P1(bar)	H(mm)	P2(bar)	t2(sec)	t3(sec)	t4(sec)	P3(bar)	t5(min)
630	9	70.0	42.0	4.5	2.8	700	25	35	42.0	85
	11	57.3	35.1	4	2.3	573	21	26	35.1	70
	13.6	46.3	28.9	3.5	1.9	463	18	22	28.9	57
	17	37.1	23.5	3.5	1.6	371	15	18	23.5	45
	17.6	35.8	22.8	3	1.5	358	14	17	22.8	44
	21	30.0	19.3	3	1.3	300	13	15	19.3	36
	26	24.2	15.7	2.5	1.0	242	11	13	15.7	30
	33	19.1	12.5	2.5	0.8	191	10	11	12.5	24

D (mm)	SDR	e(mm)	P1(bar)	H(mm)	P2(bar)	t2(sec)	t3(sec)	t4(sec)	P3(bar)	t5(min)
710	9	78.9	53.3	4.5	3.6	789	27	35	53.3	96
	11	64.5	44.6	4	3.0	645	23	31	44.6	79
	13.6	52.2	36.8	4	2.5	522	19	24	36.8	63
	17	41.8	29.9	3.5	2.0	418	16	19	29.9	52
	17.6	40.3	28.9	3.5	1.9	403	16	19	28.9	49
	21	33.8	24.5	3	1.6	338	14	17	24.5	42
	26	27.3	20.0	3	1.3	273	12	14	20.0	33
	33	21.5	15.9	2.5	1.1	215	10	11	15.9	28

D (mm)	SDR	e(mm)	P1(bar)	H(mm)	P2(bar)	t2(sec)	t3(sec)	t4(sec)	P3(bar)	t5(min)
800	9	88.9	67.7	4.5	4.5	889	30	35	67.7	108
	11	72.7	56.6	4.5	3.8	727	25	35	56.6	88
	13.6	58.8	46.7	4	3.1	588	21	26	46.7	72
	17	47.1	37.9	3.5	2.5	471	18	23	37.9	58
	17.6	45.5	36.7	3.5	2.4	455	18	21	36.7	57
	21	38.1	31.1	3.5	2.1	381	15	18	31.1	46
	26	30.8	25.3	3	1.7	308	13	16	25.3	38
	33	24.2	20.1	2.5	1.3	242	11	13	20.1	30

PE T=220°C

DVS 2207/T1 (8/15)

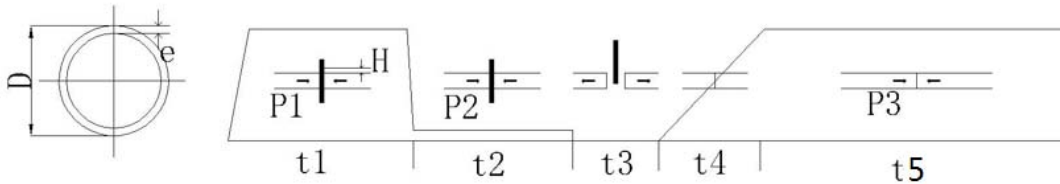
SHD1000-I (Cylinder area=38.9cm<sup>2</sup>)

D (mm)	SDR	e(mm)	P1(bar)	H(mm)	P2(bar)	t2(sec)	t3(sec)	t4(sec)	P3(bar)	t5(min)
630	9	70.0	47.5	4.5	3.2	700	25	35	47.5	85
	11	57.3	39.7	4	2.6	573	21	26	39.7	70
	13.6	46.3	32.7	3.5	2.2	463	18	22	32.7	57
	17	37.1	26.6	3.5	1.8	371	15	18	26.6	45
	17.6	35.8	25.8	3	1.7	358	15	18	25.8	44
	21	30.0	21.8	3	1.5	300	13	16	21.8	36
	26	24.2	17.8	2.5	1.2	242	11	13	17.8	30
	33	19.1	14.1	2.5	0.9	191	10	11	14.1	24

D (mm)	SDR	e(mm)	P1(bar)	H(mm)	P2(bar)	t2(sec)	t3(sec)	t4(sec)	P3(bar)	t5(min)
710	9	78.9	60.3	4.5	4.0	789	27	35	60.3	96
	11	64.5	50.4	4	3.4	645	23	30	50.4	79
	13.6	52.2	41.6	4	2.8	522	19	24	41.6	63
	17	41.8	33.8	3.5	2.3	418	16	19	33.8	52
	17.6	40.3	32.7	3.5	2.2	403	16	19	32.7	49
	21	33.8	27.7	3	1.8	338	14	17	27.7	42
	26	27.3	22.6	3	1.5	273	12	14	22.6	33
	33	21.5	17.9	2.5	1.2	215	10	11	17.9	28

D (mm)	SDR	e(mm)	P1(bar)	H(mm)	P2(bar)	t2(sec)	t3(sec)	t4(sec)	P3(bar)	t5(min)
800	9	88.9	76.5	4.5	5.1	889	30	35	76.5	108
	11	72.7	64.0	4.5	4.3	727	25	35	64.0	88
	13.6	58.8	52.8	4	3.5	588	21	26	52.8	72
	17	47.1	42.9	3.5	2.9	471	18	22	42.9	58
	17.6	45.5	41.5	3.5	2.8	455	18	21	41.5	57
	21	38.1	35.1	3.5	2.3	381	15	18	35.1	46
	26	30.8	28.7	3	1.9	308	13	16	28.7	38
	33	24.2	22.8	2.5	1.5	242	11	13	22.8	30

D (mm)	SDR	e(mm)	P1(bar)	H(mm)	P2(bar)	t2(sec)	t3(sec)	t4(sec)	P3(bar)	t5(min)
900	9	100.0	96.9	5	6.5	1000	34	35	96.9	121
	11	81.8	81.1	4.5	5.4	818	28	35	81.1	100
	13.6	66.2	66.8	4	4.5	662	23	32	66.8	80
	17	52.9	54.3	4	3.6	529	19	24	54.3	65
	17.6	51.1	52.6	4	3.5	511	19	24	52.6	62
	21	42.9	44.5	3.5	3.0	429	17	20	44.5	53
	26	34.6	36.3	3	2.4	346	14	17	36.3	43
	33	27.3	28.8	3	1.9	273	12	14	28.8	33

D (mm)	SDR	e(mm)	P1(bar)	H(mm)	P2(bar)	t2(sec)	t3(sec)	t4(sec)	P3(bar)	t5(min)
1000	9	111.1	119.6	5.5	8.0	1111	35	35	119.6	134
	11	90.9	100.1	5	6.7	909	30	35	100.1	110
	13.6	73.5	82.5	4.5	5.5	735	26	35	82.5	90
	17	58.8	67.0	4	4.5	588	21	27	67.0	72
	17.6	56.8	64.9	4	4.3	568	20	25	64.9	70
	21	47.6	54.9	3.5	3.7	476	18	23	54.9	59
	26	38.5	44.8	3.5	3.0	385	15	18	44.8	48
	33	30.3	35.6	3	2.4	303	13	15	35.6	36

PE T=220°C

DVS 2207/T1 (8/15)

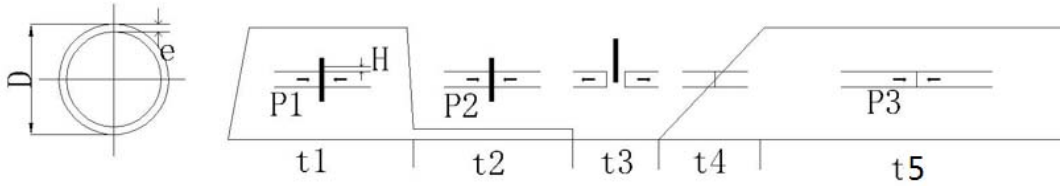

**SHD1200-I (Cylinder area=50.7cm<sup>2</sup>)**

D (mm)	SDR	e(mm)	P1(bar)	H(mm)	P2(bar)	t2(sec)	t3(sec)	t4(sec)	P3(bar)	t5(min)
630	9	70.0	36.4	4.5	2.4	700	25	35	36.4	85
	11	57.3	30.5	4	2.0	573	21	26	30.5	70
	13.6	46.3	25.1	3.5	1.7	463	18	22	25.1	57
	17	37.1	20.4	3.5	1.4	371	15	18	20.4	45
	17.6	35.8	19.8	3	1.3	358	15	18	19.8	44
	21	30.0	16.7	3	1.1	300	13	16	16.7	36
	26	24.2	13.6	2.5	0.9	242	11	13	13.6	30
	33	19.1	10.8	2.5	0.7	191	10	11	10.8	24

D (mm)	SDR	e(mm)	P1(bar)	H(mm)	P2(bar)	t2(sec)	t3(sec)	t4(sec)	P3(bar)	t5(min)
710	9	78.9	46.3	4.5	3.1	789	27	35	46.3	96
	11	64.5	38.7	4	2.6	645	22	30	38.7	79
	13.6	52.2	31.9	4	2.1	522	19	24	31.9	63
	17	41.8	25.9	3.5	1.7	418	16	19	25.9	52
	17.6	40.3	25.1	3.5	1.7	403	16	19	25.1	49
	21	33.8	21.2	3	1.4	338	14	17	21.2	42
	26	27.3	17.3	3	1.2	273	12	14	17.3	33
	33	21.5	13.8	2.5	0.9	215	10	11	13.8	28

D (mm)	SDR	e(mm)	P1(bar)	H(mm)	P2(bar)	t2(sec)	t3(sec)	t4(sec)	P3(bar)	t5(min)
800	9	88.9	58.7	4.5	3.9	889	30	35	58.7	108
	11	72.7	49.1	4.5	3.3	727	25	35	49.1	88
	13.6	58.8	40.5	4	2.7	588	21	26	40.5	72
	17	47.1	32.9	3.5	2.2	471	18	22	32.9	58
	17.6	45.5	31.9	3.5	2.1	455	18	22	31.9	57
	21	38.1	27.0	3.5	1.8	381	15	18	27.0	46
	26	30.8	22.0	3	1.5	308	13	16	22.0	38
	33	24.2	17.5	2.5	1.2	242	11	13	17.5	30

D (mm)	SDR	e(mm)	P1(bar)	H(mm)	P2(bar)	t2(sec)	t3(sec)	t4(sec)	P3(bar)	t5(min)
900	9	100.0	74.3	5	5.0	1000	32	35	74.3	121
	11	81.8	62.2	40.5	4.1	818	28	35	62.2	100
	13.6	66.2	51.3	4	3.4	662	23	32	51.3	80
	17	52.9	41.7	4	2.8	529	19	24	41.7	65
	17.6	51.1	40.3	4	2.7	511	19	24	40.3	62
	21	42.9	34.1	3.5	2.3	429	17	20	34.1	53
	26	34.6	27.8	3	1.9	346	14	17	27.8	43
	33	27.3	22.1	3	1.5	273	12	14	22.1	33

D (mm)	SDR	e(mm)	P1(bar)	H(mm)	P2(bar)	t2(sec)	t3(sec)	t4(sec)	P3(bar)	t5(min)
1000	9	111.1	91.8	5.5	6.1	1111	35	35	91.8	134
	11	90.9	76.8	5	5.1	909	30	35	76.8	110
	13.6	73.5	63.3	4.5	4.2	735	25	35	63.3	90
	17	58.8	51.4	4	3.4	588	21	26	51.4	72
	17.6	56.8	49.8	4	3.3	568	20	25	49.8	70
	21	47.6	42.1	3.5	2.8	476	18	23	42.1	59
	26	38.5	34.4	3.5	2.3	385	15	18	34.4	48
	33	30.3	27.3	3	1.8	303	13	15	27.3	36

D (mm)	SDR	e(mm)	P1(bar)	H(mm)	P2(bar)	t2(sec)	t3(sec)	t4(sec)	P3(bar)	t5(min)
1100	9	122.2	111.0	5.5	7.4	1222	35	35	111.0	147
	11	100.0	92.9	5	6.2	1000	32	35	92.9	121
	13.6	80.9	76.6	4.5	5.1	809	27	35	76.6	98
	17	64.7	62.2	4	4.1	647	22	30	62.2	79
	17.6	62.5	60.2	4	4.0	625	22	29	60.2	77
	21	52.4	51.0	4	3.4	524	19	24	51.0	63
	26	42.3	41.6	3.5	2.8	423	16	19	41.6	52
	33	33.3	33.0	3	2.2	333	14	17	33.0	40

D (mm)	SDR	e(mm)	P1(bar)	H(mm)	P2(bar)	t2(sec)	t3(sec)	t4(sec)	P3(bar)	t5(min)
1200	9	133.3	132.1	5.5	8.8	1333	35	35	132.1	157
	11	109.1	110.6	5	7.4	1091	34	35	110.6	132
	13.6	88.2	91.1	4.5	6.1	882	29	35	91.1	107
	17	70.6	74.1	4.5	4.9	706	25	35	74.1	86
	17.6	68.2	71.7	4	4.8	682	24	34	71.7	83
	21	57.1	60.7	4	4.0	571	20	25	60.7	70
	26	46.2	49.5	3.5	3.3	462	18	22	49.5	57
	33	36.4	39.3	3	2.6	364	15	18	39.3	44

## **ROTHENBERGER Quality Certificate**

**Dear Customer,**

Before delivering your product we have tested your welding machine.

- SHD800-I
- SHD1000-I
- SHD1200-I

The welding machine meets the ROTHENBERGER quality standards and is released for the competent use.

Date: \_\_\_\_\_

Signature: Fred.Z